

TB163 (Rev1) - Single Phase Operation of Centroid Controls

A phase converter is not recommended or needed for running most controls using single phase. Most 3-phase motors can be operated using an Inverter for less cost than a noisy phase converter.

Main control

DC servo systems made after January 1, 1995 are designed to use single phase to power the main servo control. The L1 line is not used by the control. It is only used to power 3-phase motors. For single-phase operation make sure that power is connected to L2 and L3.

AC servo systems can also be powered from L2 and L3. Single-phase operation is not recommended for systems using servomotors over 1kW. Systems with only 2 axis can use up to 2kW motors although most systems that use larger servo motors also use larger spindle motors and the use of single phase for spindle motors over 7.5hp is not practical.

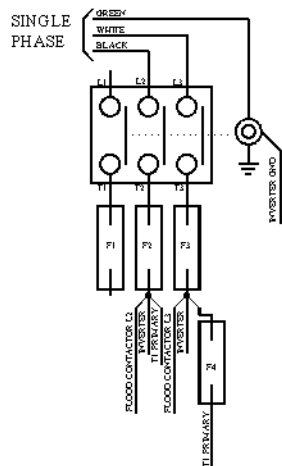

Spindle motor operation with single phase.

1. Spindle motors of 7.5hp or less can be run using single-phase power. Spindle motors higher than 7.5hp require too much current (Over 100amps) to be practically run with single phase.
2. An inverter is recommended for spindle operation. Replacing reversing contactors with an inverter is less expensive than a phase converter. (A 5hp inverter is around \$450) Most controls can be set up for spindle speed control but the inverter can be used to just turn the spindle on and off also.
3. An inverter capable of single-phase operation must be used. The following inverters will work.
 - * Mitsubishi FR-A500 series for ATC units.
 - * Hitachi SJ100 series
 - * Automation Direct GS1 and GS2
4. For other models consult the manufacturer to find out if they are capable of single-phase operation.
5. Oversize the inverter accordingly.

3 phase Spindle motor size	1.5 Hp	2 Hp	3 Hp	5 Hp	7.5 Hp
Inverter size needed	2 HP	3 Hp	5 Hp	7.5 Hp	10 Hp

6. For proper connection of an inverter for single-phase operation refer to the inverter manual. Different inverters use different connections for single-phase operation.

To run a 3-phase flood pump using single-phase, an inexpensive inverter (\$100) can be used to run the flood pump in place of a contactor. The output of the inverter is set to 60Hz and the output on the PLC is used to turn the inverter on and off. Disconnect the original contactor control wires and connect the inverter control wires as shown.

(NOTE) A RTK2 PLC has 24vac internally provided on the flood output. It would require the use of a 24vac relay or contactor to turn the inverter on and off. All other PLC types are a simple switch closure. Except for the RTK2 PLC, disconnect the original contactor control wires and connect the inverter control wires as shown.

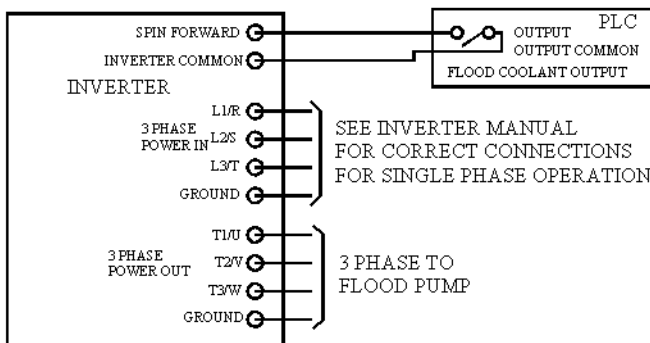

To run a single-phase flood pump the overload protector on the flood contactor must be removed and replaced with the correct size fuses.

SINGLE PHASE

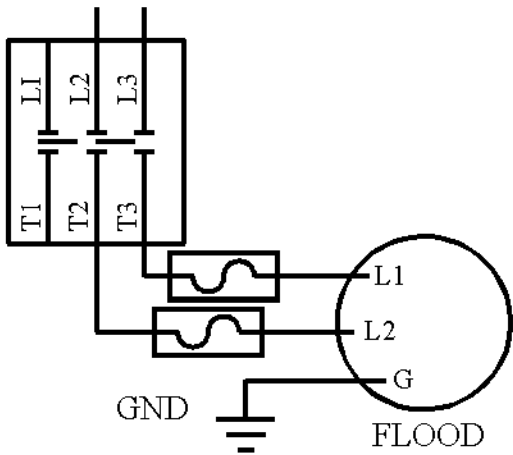

To run a 3-phase ATC Carousel motor with a PLCIO2 using single-phase an inexpensive inverter (\$100) can be used to run the carousel motor. The output of the inverter is set to 60Hz and the outputs on the PLC are used to turn the inverter on and off. Disconnect the original contactor control wires and connect the inverter control wires as shown.

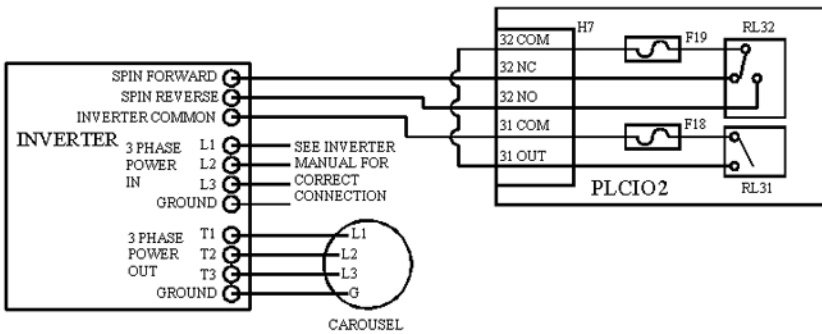

To run a 3-phase ATC Carousel motor and flood pump with a RTK3 PLC using single-phase an inexpensive inverter (\$100) can be used to run the carousel motor and another inverter to run the flood pump motor. The output of the inverters is set to 60Hz and the outputs on the PLC are used to turn the inverters on and off. Disconnect the original power wires and connect the inverter control wires as shown.

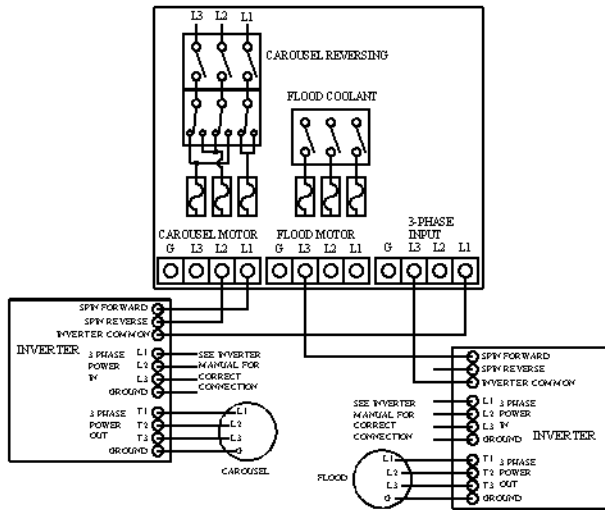

To use a single-phase reversing carousel motor with a PLCIO2 PLC. Connect the incoming single-phase power and motor wires as shown without changing the contactor control wires.

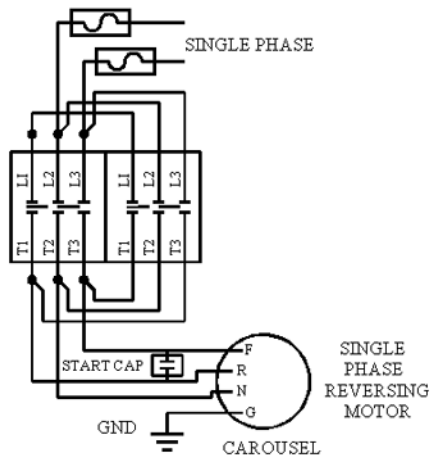

To use a single-phase reversing carousel motor and single-phase flood pump motor with a RTK3 PLC. Connect the incoming single-phase power and motors as shown.

