

TB107 (Rev1) - Adjusting ATC Tool Pullstud Clamp

Overview

This is a step-by-step procedure for adjusting the tool pullstud clamping mechanism such as the one found on the Atrump B5 and B6 ATC bedmills.

Problem

On several of the Atrump ATC mills the tool holders will not release properly from the spindle taper. This is caused by an improperly adjusted pullstud clamping mechanism located on the spindle. Follow the procedure below to correctly adjust the tool clamp.

Procedure

1. Remove the side panel of the spindle cover from the spindle. This will give you access to the tool clamping assembly located above the spindle cartridge. View figure 1.

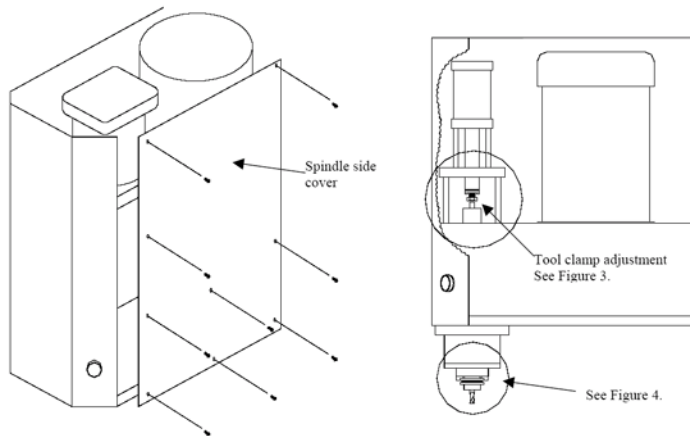

Figure 1

2. Unplug the electrical connector from the spindle air blow through solenoid located on the left side of the main column on the mill. This will be the only solenoid valve that has a port capped off and should be the first valve in the solenoid pack, as illustrated in **figure 2**. This will prevent the spindle blow through from interfering with the tool clamp adjustment.

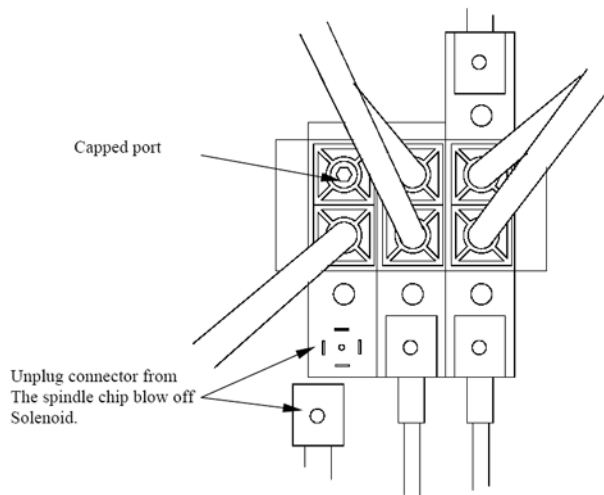

Figure 2

3. Loosen the two small cap head screws on each side of the large end adjustment bolt located on the bottom end of the air cylinder shaft, as illustrated in **figure 3**. This will allow the large center bolt to be adjusted.

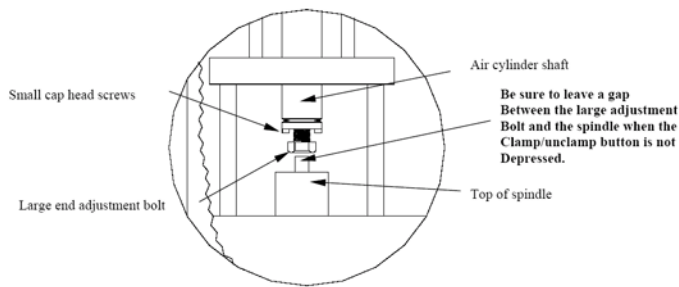

Figure 3

4. Insert a tool holder into the spindle while holding the tool clamp/unclamp button located on the front right hand side of the spindle housing.

5. Release the tool clamp/unclamp button and make sure the tool holder is securely held in the spindle.

6. Turn the large end adjustment bolt located on the air cylinder shaft until the tool holder, held in the spindle, moves at least 1/16" away from the spindle when ever the clamp/unclamp button is pressed, but not more than 3/32" from the spindle. Refer to **figure 4**. After you have made the proper adjustment the tool holder should release easily from the spindle when the clamp/ unclamp button is depressed. **There should always be a gap between the large adjustment bolt and the top of the spindle when the clamp/unclamp button is not depressed, because the bolt remains stationary and the spindle rotates, if there is not then you have adjusted the large bolt too far down!**

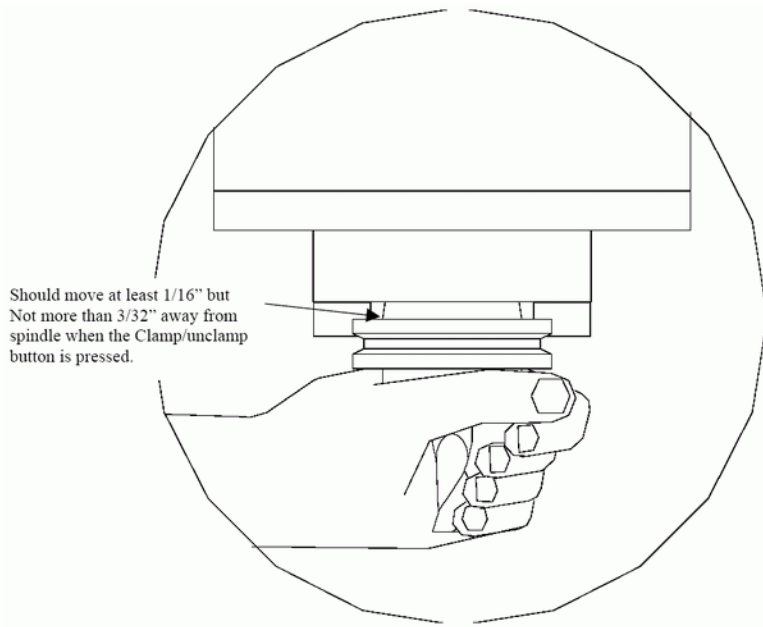

Figure 4

7. Tighten down the two small cap head screws on each side of the large adjustment bolt, reinstall the spindle housing side cover and reconnect the spindle blow through solenoid connector on the rear column. This completes the adjustment.

Document History

Rev1 Created on **2001-01-05**